



GERKIN™
WINDOWS & DOORS

Shooting The Breeze



VOLUME:
05

ISSUE:
01

SPRING:
16

in this issue:



Custom Rhino

Page 2



Model 6600

Page 3



New Staff

Page 4



Dark Bronze "DB" Exterior Now Available on Comfort Series

We are pleased to announce the addition of a dark bronze exterior color for many of our Comfort Series windows and doors. We will refer to this new color as "DB". Choosing a dark color that won't fade or age with time was not an easy task. Many vinyl window companies use paint or PVC films that easily fade, chalk, crack and scratch.

Gerkin chose an acrylic based printed film called EXOFOL. There is a monumental difference in performance between our acrylic based film and PVC film or paint.

The adhesive used on the acrylic wrap forms a solid bond when exposed to air and becomes one with the vinyl. It cannot be removed once it is set. This eliminates any possibility of peeling. The solid acrylic base reduces heat absorption, is UV resistant and withstands prolonged exposure to heat. The top of the base layer is pigmented throughout using "Solar Shield Technology" (SST) which reflects the sun's rays and lowers the heat buildup. There are two transparent protective layers above the base film which is weather resistant and protects against UV irradiation.

The key to performance is moisture resistance. Gerkin's PVDF top layer is more resistant to moisture absorption over PVC films and paint. PVC films crack and fail over time due to moisture.

Gerkin's EXOFOL is unaffected by environmental pollutants, and is virtually self-cleaning with rain. It is even graffiti resistant, so virtually everything can be cleaned off the EXOFOL.

EXOFOL is best known for fade resistance. There is no fading that can be seen by the naked eye after 22,000 hours of intense UV testing on the dark bronze color we have chosen. That is equivalent to over 20 years of exterior weathering. After this extensive weathering, the gray scale grade on Gerkin's dark bronze is 4. (5 is the original color) This means a color change is barely visible. By comparison, painted finishes will fade to a gray scale of 3 in just 4 years. PVC based foils show visible fading after just 5 years and show complete failure in color and stability after just 10 years in natural weathering tests. EXOFOL shows no difference in color or stability over the same period.

The Comfort Series products that are available in the dark bronze exterior are, casements, awnings, sliders, sliding patio doors and matching fixed windows, side lites and transoms. We are ready to take orders on these products.

For more information, contact your Gerkin representative.

WHAT'S NEW

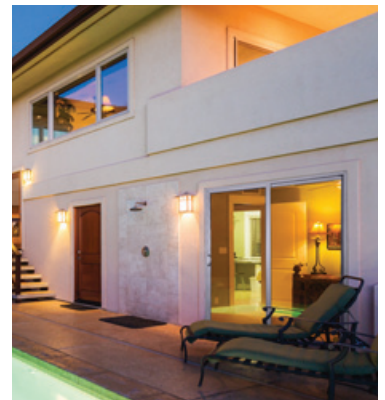
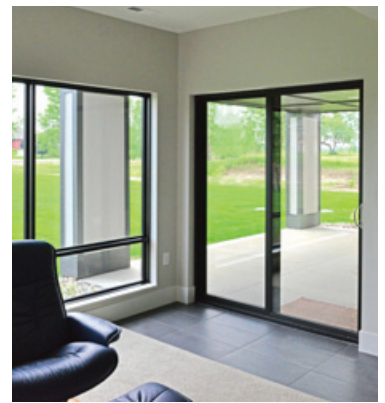
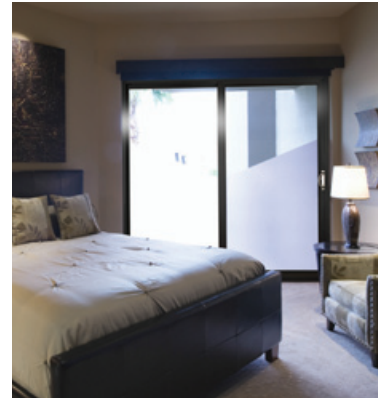

Custom Size Rhino Patio Doors, Transoms and Sidelights

In 2015, Gerkin introduced a new easy to install factory assembled aluminum sliding glass door. Now we have expanded our offerings to include custom sizes! We will custom build our doors practically any size from 5068 to 8080. There are no quantity minimums! Call Gerkin for a quote.

The sliding glass doors can now be paired with our model 58F

fixed window system! With this option, we can offer banks of windows and doors all field mullered together. Transom sizes up to an 8040 over an 8080 door are now available!

There are nearly limitless size and configuration options that can be used to create your own wall of glass for either a modern home or a commercial enclosure.

WHAT'S NEW



Model 6600 Swing Patio Door

Gerkin has upgraded its swing doors

When only the best will do, Gerkin is the right choice when looking at swing patio doors! We offer a new atrium style door. This door is a terrific performer and offers some high quality standard features. All doors come with a multi-point lock and deadbolt for a secure and tight fit. They also have solid hinges that never need adjusting! The weather-stripping is a compression seal along with a unique "rain-shed" design at the sill. True to Gerkin form, all stiles and rails are aluminum reinforced for a structure that can't be beat!

All Gerkin swing doors include low E glass with argon gas as a standard feature.

Gerkin stocks this door in white and tan in a 72 x 80 size with XO and OX operations. Call Gerkin for custom size options.

When great looks and terrific performance are at the top of your priority list for swing patio doors, look no further than the Gerkin model 6600!

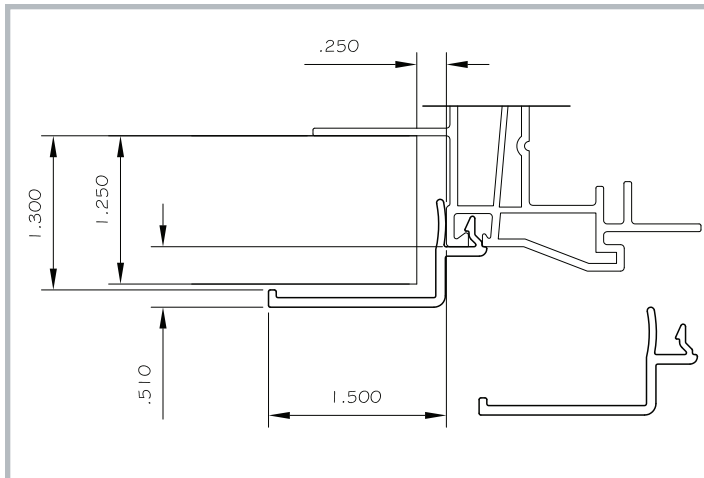

New J-Channel

We have recently introduced an all new j-channel accessory for our Comfort Series vinyl windows. We now have two j-channel options to choose from. Our new j-channel allows for wider siding to be used (up to 1 1/4") and it gives more of a decorative trim look. To order the new j-channel, just ask for the "wide pocket" j-channel.

NEW SALES TEAM



Craig Galyon

Craig Galyon joined the Gerkin sales staff in early 2015. Craig is working out of his office in Plainfield, IL. Craig is responsible for all Gerkin product sales in Central and Northern Illinois as well as Wisconsin.

Craig is a veteran in the window industry. He has worked in the window business most of his career. He has sold for other window manufacturers calling on dealers and distributors in Illinois and Southern Wisconsin. He is working a territory that he is very familiar with and already knew many of the Gerkin dealers before he started. Craig is off to a great start with us and we are looking forward to building many long lasting partnerships in his territory.

Craig can be reached at his Illinois Gerkin office at 630-632-8676. His e-mail address is cgalyon@gerkin.com.



Jim Gagin

Jim Gagin joined the Gerkin sales staff in early 2015. Jim is working out of his office in Littleton, CO. Jim is responsible for all Gerkin product sales in Colorado, Wyoming and the Panhandle of Nebraska.

Jim has a wealth of previous sales experience in the building material trade. His experience has come from the manufacturing side of the business in working with architectural translucent panels. His success in working through distribution and working with architects through AIA presentations and project specifications has made Jim a great fit for Gerkin. We are looking forward to expanding the Gerkin brand in the mountain states with Jim's help.

Jim can be reached at his Gerkin office at 303-949-6434. His e-mail address is jgagin@gerkin.com.

OUR COMMITMENT

Quality since 1932

Our mission is to manufacture high quality window and door products that are value priced, thermally efficient and low maintenance. Throughout our history we have established ourselves as an innovator in the design and manufacturing capability of insulated windows and doors. Stringent product testing and innovative design has allowed our products to evolve as market and consumer needs change, bringing you the quality, maintenance-free products you desire. We also publish our AAMA test results to back up our claims of product performance and quality.



P.O. BOX 3203 SIOUX CITY, IA 51102
PHONE: 402.494.6000 FAX: 402.494.6765 TOLL FREE: 800.475.5061